

THIS DOCUMENT IS THE PROPERTY OF FABCO INDUSTRIES AND IS CONVEYED WITH THE EXPRESS CONDITION THAT IT AND THE INFORMATION CONTAINED IN IT ARE NOT TO BE USED, DISCLOSED, OR REPRODUCED IN WHOLE OR IN PART, FOR ANY PURPOSE WITHOUT THE EXPRESS WRITTEN CONSENT OF FABCO INDUSTRIES, AND THAT NO RIGHT IS GRANTED TO DISCLOSE OR SO USE ANY INFORMATION CONTAINED IN SAID DOCUMENT.

REVISIONS			
REV	DESCRIPTION	DATE	APPROVED
G	ECN9794-1-000_G	07/19/2013	

NOTES:

- WEIGHT: 25 LB MAX.
- MATERIAL:
  - SUPPORT FLANGE/SHROUD: ALUMINUM ALLOY 6061-T6 / HDPE
  - CORNER BRACE: ALUMINUM ALLOY 6061-T6
  - SUPPORT HUB: CRS, POWDER COATED
  - SACK MATERIAL: WOVEN POLYPROPYLENE GEOTEXTILE (20 US MESH)
  - HARDWARE: ALUMINUM RIVETS, CRS WASHERS
- PERFORMANCE CHARACTERISTICS (TYP):
  - DEBRIS CAPACITY: 3.6 CU-FT
  - FILTERED FLOW RATE: 2217 GPM (4.9 CFS)
  - BYPASS FLOW RATE: 1059 GPM (2.4 CFS)
- MINIMUM REQUIRED CLEAR SPACE: 22' X 22'
- PROTECTED BYPASS PREVENTS RE-SUSPENSION OF FLOATABLES.
- RECOMMENDED MINIMUM VAULT DEPTH: 2-IN BELOW SACK.
- TYPICAL INSTALLATION: REMOVE STORM GRATE, INSTALL STORMSOK DIRECTLY ON GRATE SUPPORT LEDGE, REINSTALL STORM GRATE.
- USE ONLY FABCO REPLACEABLE STORMSOK ASSEMBLY. P/N: 9792-1-200.

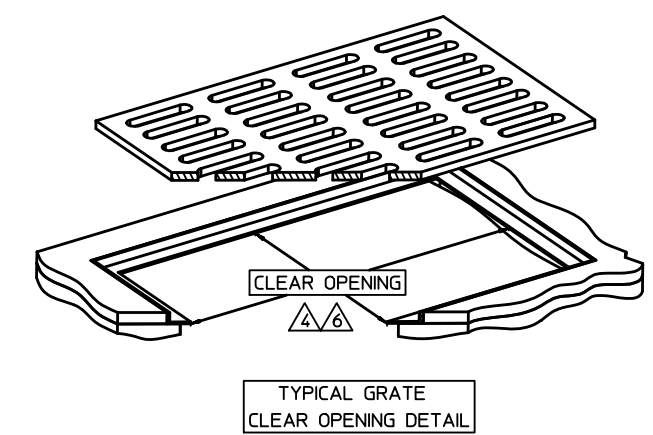
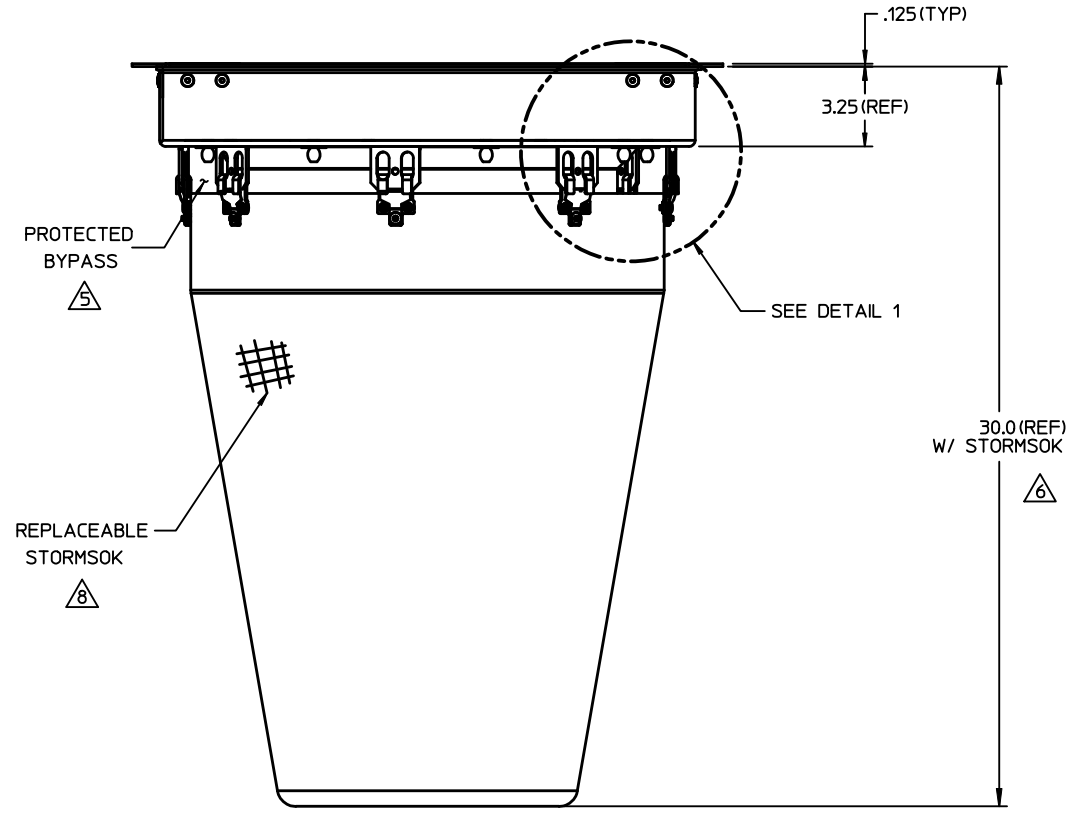
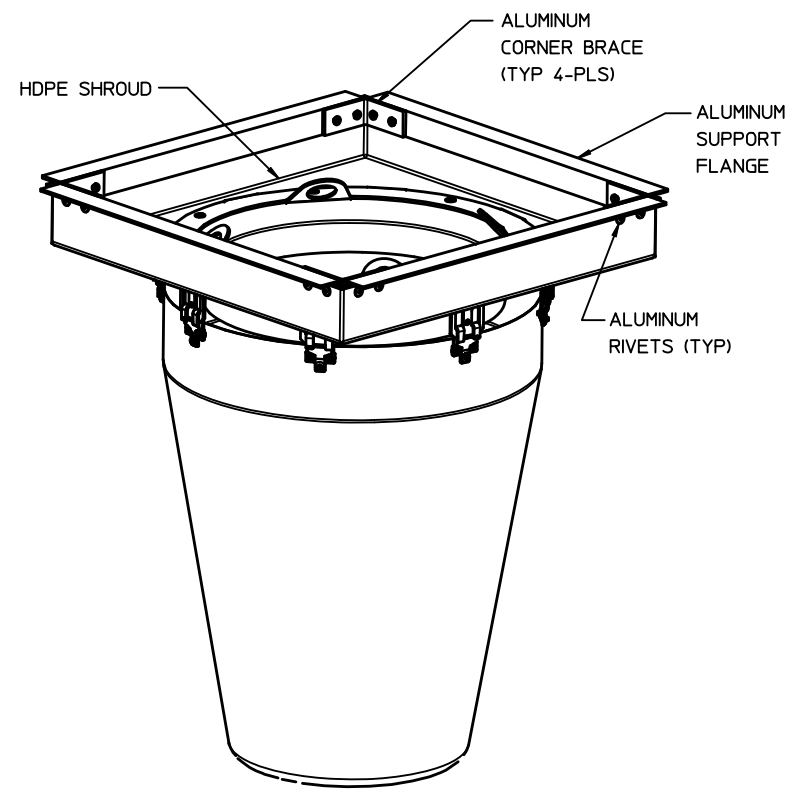
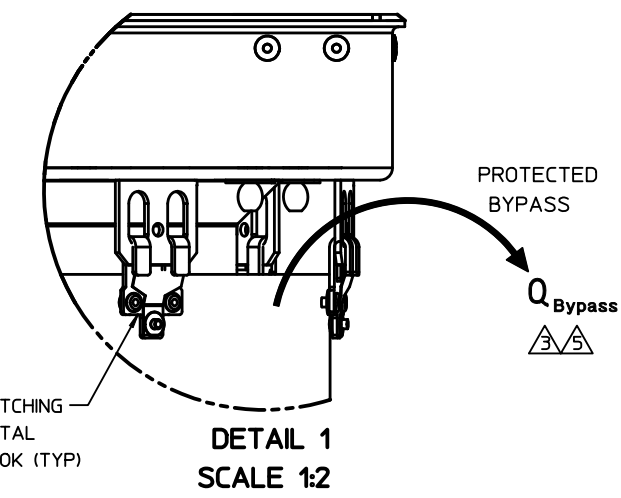
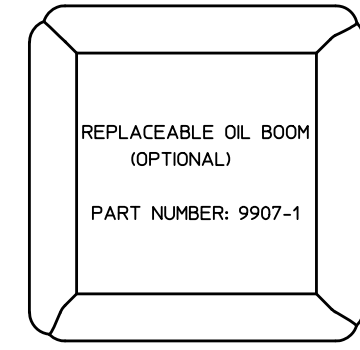
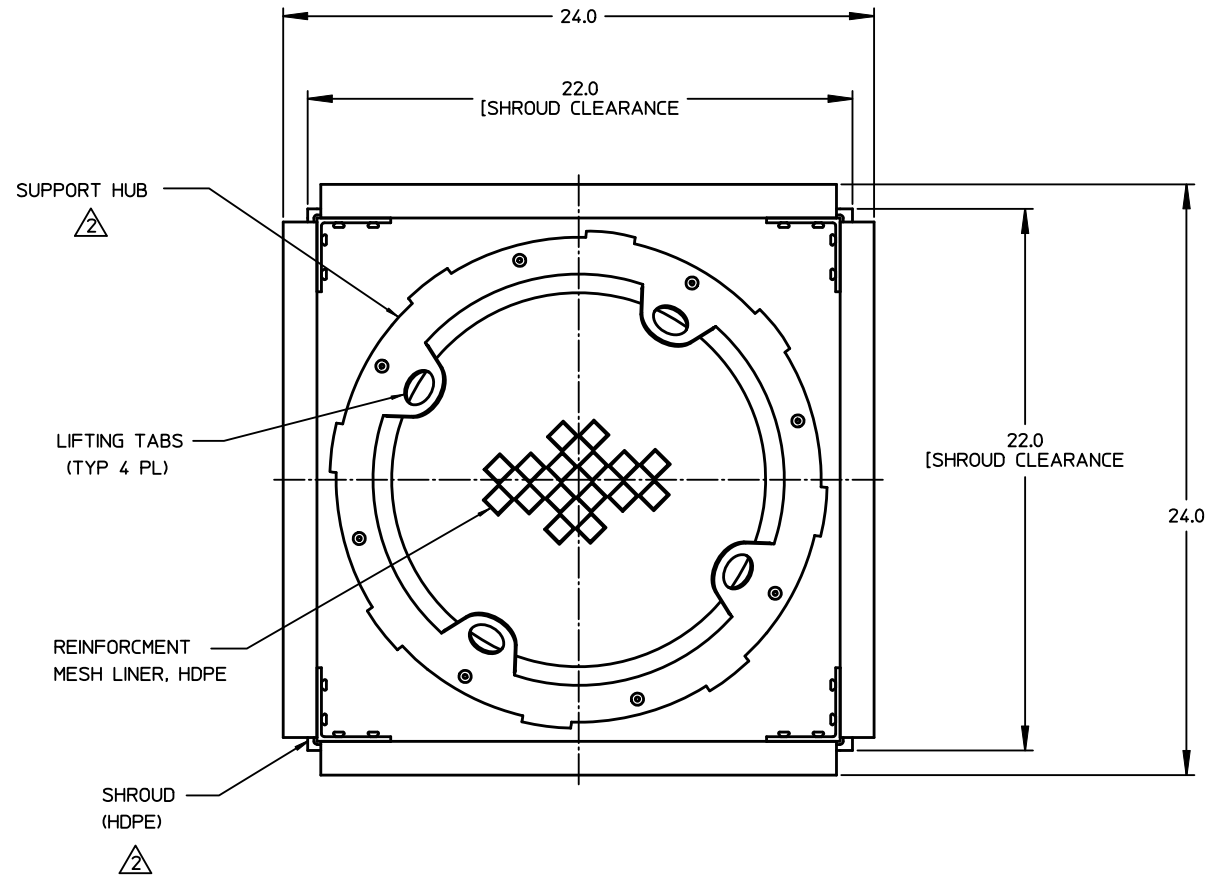

NO	QTY	PART NUMBER	DESCRIPTION	REMARKS								
<b>BILL OF MATERIALS</b>												
UNLESS OTHERWISE SPECIFIED REMOVE ALL BURRS BREAK SHARP EDGES .002 - .020 FILLETS .020 MAX DIMENSIONS ARE IN INCHES AND INCLUDE CHEMICALLY APPLIED OR PLATED FINISHES DO NOT SCALE THIS DRAWING		TOLERANCES: DEC .00 + .01 DEC .000 + .005 FRACT ± 1/16 ANGLE ± 2° Rd FINISH ✓		<table border="1"> <thead> <tr> <th>APPROVALS</th> <th>DATE</th> </tr> </thead> <tbody> <tr> <td>DWN N.NEUWIRTH</td> <td>04/11/08</td> </tr> <tr> <td>CHKR S.GORNEAU</td> <td>8/22/12</td> </tr> <tr> <td>ENGR J. PETERS</td> <td>04/11/08</td> </tr> </tbody> </table>	APPROVALS	DATE	DWN N.NEUWIRTH	04/11/08	CHKR S.GORNEAU	8/22/12	ENGR J. PETERS	04/11/08
APPROVALS	DATE											
DWN N.NEUWIRTH	04/11/08											
CHKR S.GORNEAU	8/22/12											
ENGR J. PETERS	04/11/08											
MATERIAL		APVD		TITLE								
SEE NOTES		FABCO INDUSTRIES, INC. 66 CENTRAL AVE FARMINGDALE, NY 11735 WWW.FABCO-INDUSTRIES.COM		STORMSOK, 22' X 22' CS								
MODEL LINK		SIZE	CAGE CODE	DWG NO								
9794-1_ASSY1		D	1P8A4	9794-1-000								
		SCALE	1/4" = 1"	REV G								
				SHEET 1 OF 1								

