

NOTES:

1.0 WEIGHT ESTIMATE:

- 1.1 COVER: 21,000 - LB (10.5 TONS)
- 1.2 BASE: 51,600 - LB (25.8 TONS)

2.0 VAULT:

- 2.1 REINFORCEMENT STEEL: NYSDOT 709.04 GRADE 60, ASTM A-615 OR EQUIVALENT.
- 2.2 CONCRETE MATERIALS: NYSDOT STANDARD SPECIFICATION SECTION 704-03 PRECAST CONCRETE GENERAL, EXCEPT THE CONCRETE SHALL HAVE A MINIMUM COMPRESSIVE STRENGTH OF 28 MPA AT THE END OF 28 DAYS.
- 2.3 ACCESS MANHOLES: ASTM-A-48, CLASS 35B GRAY IRON OR ASTM A536, GRADE 80-55-06 DUCTILE IRON.
- 2.4 FILTER HOUSING: HDPE CORRUGATED PIPE
- 2.5 HELICAL FILTER ELEMENTS: CRS WIRE FRAME W/TREATED T20 FOAM COVER.

3.0 CONCRETE STRUCTURE DESIGNED TO MEET OR EXCEED H-20 LOAD RATING.

4.0 PERFORMANCE CHARACTERISTICS (REF):

- 4.1 FILTERED FLOW RATE: 9 CFS (4050 GPM)
- 4.2 BYPASS FLOW RATE: GREATER THAN FLOW THROUGH OUTLET PIPE

5.0 ACCESS MANHOLES ARE SUPPLIED SEPARATELY WITH THE STORMSAFE. ALTERNATE (LARGER) ACCESS HATCHES ARE AVAILABLE IF LIGHT DUTY OR PEDESTRIAN LOAD RATINGS ARE ACCEPTABLE BY THE PROJECT ENGINEER. EJIW #1581 & EJIW #1480 CASTINGS ARE RECOMMENDED FOR REPEATED VEHICULAR TRAFFIC AND CONFORM TO AASHTO M306 STANDARDS. FINAL MANHOLE OR ACCESS HATCH INSTALLATION, AND ADJUSTMENT TO GRADE, SHALL BE PERFORMED BY QUALIFIED PERSONNEL.

6.0 OFFLOADING, EXCAVATION, DEWATERING, DRAINAGE FILL, AND BACKFILL OPERATIONS SHALL BE PERFORMED IN ACCORDANCE WITH OSHA AND LOCAL REGULATIONS AND ARE THE RESPONSIBILITY OF THE CONTRACTOR. SUB-BASE AND BACKFILL DEPTH ARE SITE SPECIFIC AND SHALL BE SPECIFIED BY THE ENGINEER OF RECORD.

7.0 THE CONTRACTOR SHALL VERIFY THAT THE UNIT IS VERTICALLY AND HORIZONTALLY PLUMB AND STABLE, WITH MINIMUM VOIDS AND MINIMUM UN-COMPACTED SOIL AFTER BACK FILL OPERATION.

8.0 AFTER REMOVING SKIN-KNOCKOUT FROM VAULT, CONNECT EXISTING PIPE TO HELIX VAULT INLET AND OUTLET PORTS WITH APPROVED NON-SHRINKING GROUT-FILL IN ACCORDANCE WITH MANUFACTURERS INSTRUCTIONS. HELIX VAULT "INLET" AND "OUTLET" PORTS ARE CLEARLY LABELED WITH BLACK PAINT. EXISTING INLET/OUTLET PIPE TO BE ALIGNED FLUSH WITH RESPECTIVE INTERIOR VAULT WALLS.

9.0 MAINTENANCE AND HELICAL FILTER REPLACEMENT INSTRUCTIONS ARE PROVIDED SEPARATELY AND ARE SITE SPECIFIC.

10.0 HELICAL FILTER REPLACEMENT (IN GENERAL):

FOR BEST PERFORMANCE REPLACE HELICAL FILTERS IAW FABCO RECOMMENDATIONS. HIGH CONTAMINANT LOCATIONS MAY REQUIRE MORE FREQUENT FILTER REPLACEMENT. REMOVE ANY DEBRIS OR HEAVY SEDIMENT FROM THE INFLUENT CHAMBER. REMOVE THE INLET DIFFUSER AND SLIDE EACH HELICAL FILTER SEGMENT OUT OF THE FILTER HOUSING. INSERT THE REPLACEMENT HELICAL FILTERS. EACH HOUSING REQUIRES FIVE (5) HELICAL FILTER SEGMENTS, DISPOSE OF USED FILTER MEDIA IN ACCORDANCE WITH LOCAL REGULATION.

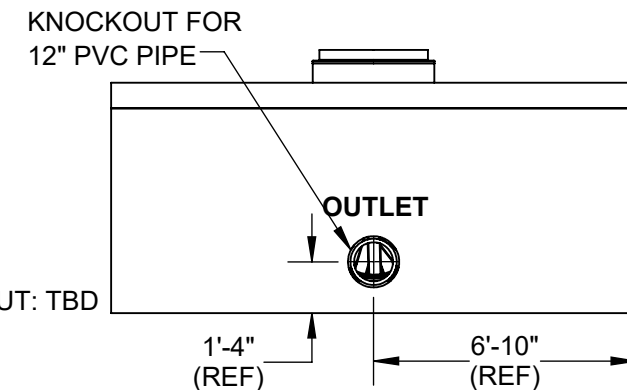
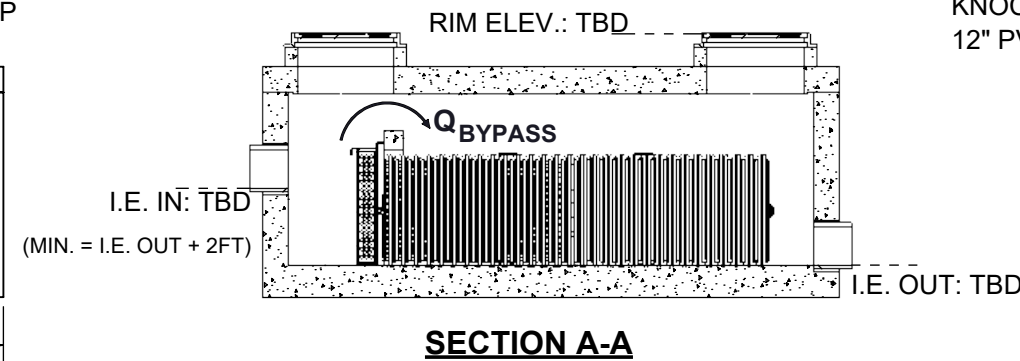
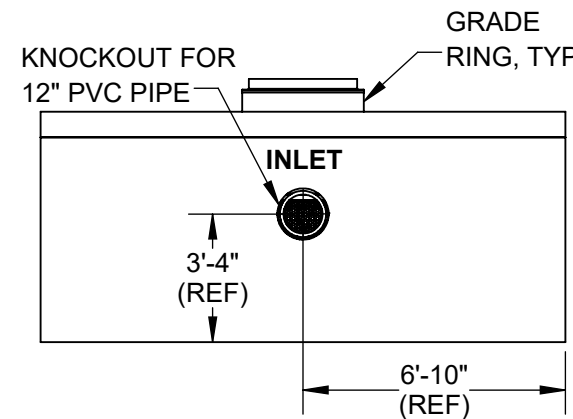
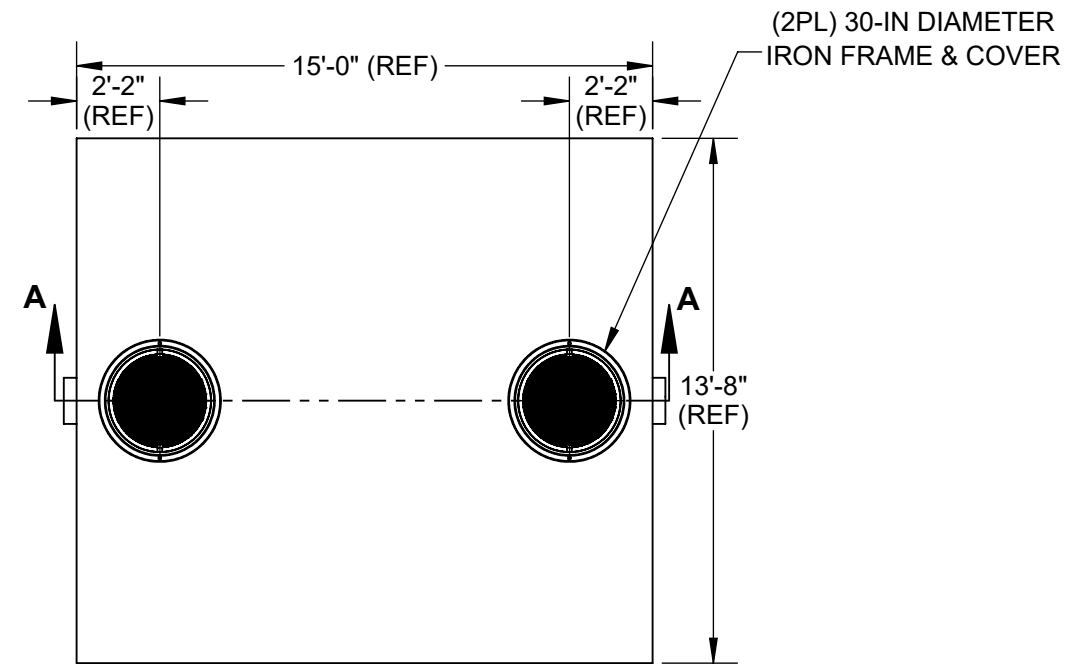
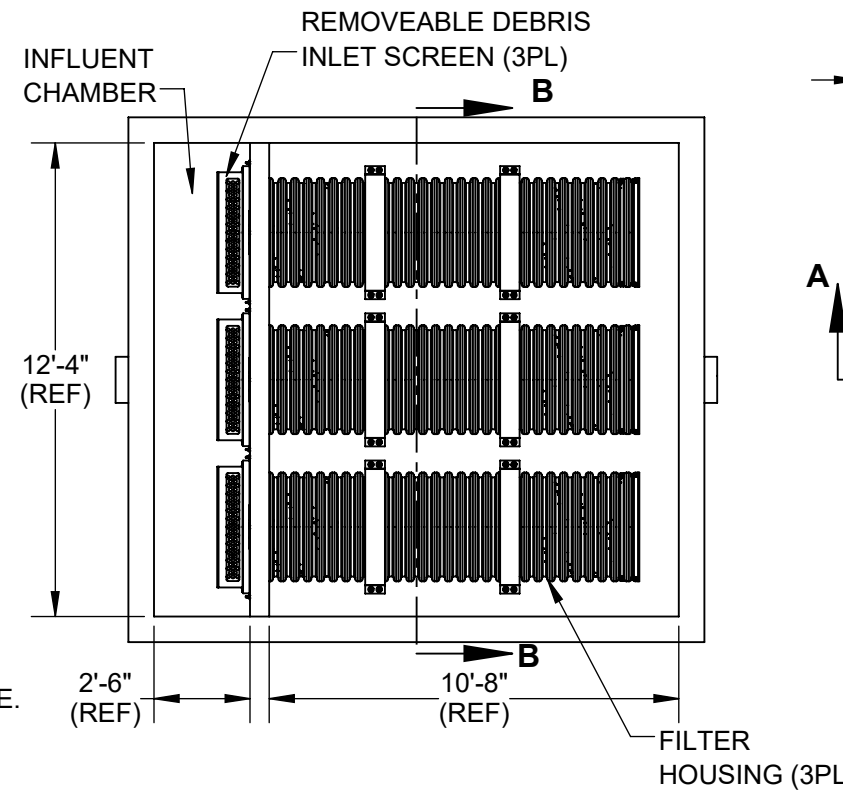

FRAME & COVER FINAL GRADE ADJUSTMENT TO BE MADE BY QUALIFIED FIELD PERSONNEL

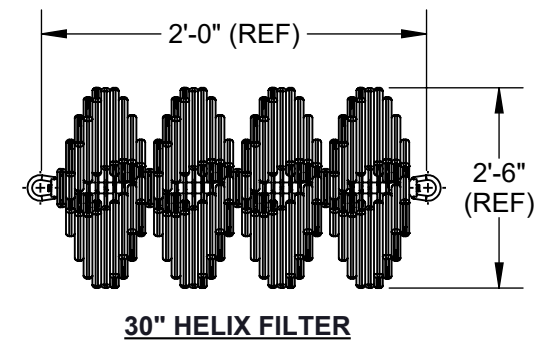
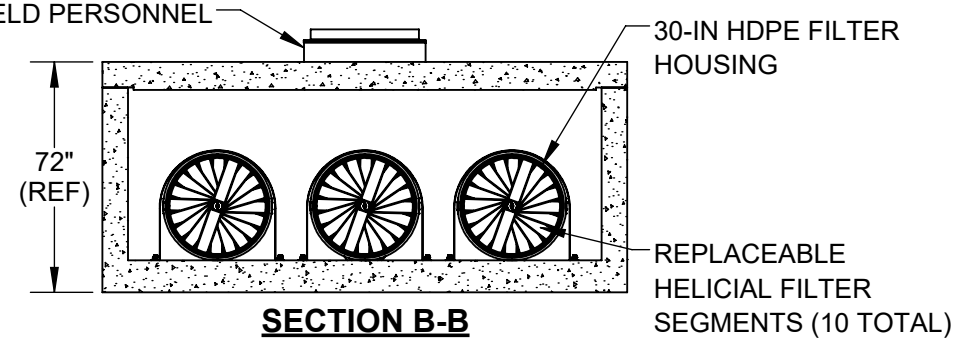

<p>PROPRIETARY AND CONFIDENTIAL THIS DOCUMENT IS THE PROPERTY OF FABCO INDUSTRIES AND IS CONVEYED WITH THE EXPRESS CONDITION THAT IT AND THE INFORMATION CONTAINED IN IT ARE NOT TO BE USED, DISCLOSED, OR REPRODUCED IN WHOLE OR IN PART, FOR ANY PURPOSE WITHOUT THE EXPRESS WRITTEN CONSENT OF FABCO INDUSTRIES; AND THAT NO RIGHT IS GRANTED TO DISCLOSE OR SO USE ANY INFORMATION CONTAINED IN SAID DOCUMENT.</p>	<p>UNLESS OTHERWISE SPECIFIED REMOVE ALL BURRS BREAK SHARP EDGES .002 - .020 FILLETS .020 MAX DIMENSIONS ARE IN INCHES AND INCLUDE CHEMICALLY APPLIED OR PLATED FINISHES</p>	<p>TOLERANCES: DEC .00 ± .01 DEC .000 ± .005 FRACT ± 1/16 ANGLE ± 2°</p>	<p>APPROVAL DATE DWN R.W. 4/14/2023 CHKR ENGR J.P. 4/14/2023 UPD</p>	<p>FABCO industries inc TYPICAL TRIPLE TUBE HELIX SIZE DWG. NO. VHB30.3-2-000 SCALE: NONE SHEET 1 OF 1</p>
	<p>PROJECT EXAMPLE</p>	<p>FABCO INDUSTRIES, INC. 24 CENTRAL DRIVE FARMINGDALE, NY 11735 WWW.FABCO-INDUSTRIES.COM</p>	<p>REV A</p>	
	<p>MATERIAL</p>	<p>REPLACEABLE HELICAL FILTER SEGMENTS (10 TOTAL)</p>	<p>REV A</p>	
	<p>REPLACEABLE HELICAL FILTER SEGMENTS (10 TOTAL)</p>	<p>REPLACEABLE HELICAL FILTER SEGMENTS (10 TOTAL)</p>	<p>REV A</p>	