

GENERAL INSTALLATION:
 ADJUST THE TURNBUCKLE DOWN TO GIVE THE SMALLEST RING DIAMETER AND LOCATE THE EXPANSION RING INTO THE HARCO STRUCTURE MINIMUM OF 6-IN DOWN FROM THE TOP OPENING AS SHOWN. BEGIN OPENING THE TURNBUCKLE UNTIL THE EXPANSION RING IS SELF SUPPORTING, THEN VERIFY THE RING IS LEVEL AND PLUMB TO THE HARCO STRUCTURE. USING A CALIBRATED TORQUE WRENCH, CONTINUE TO OPEN THE TURNBUCKLE TO 13 FT-LB (+/- 0.5 FT-LB) TORQUE. DO NOT OVER TIGHTEN. PLACE THE TRANSITION PLATE ON THE EXPANSION RING AND SECURE WITH SELF DRILLING SCREWS PROVIDED. INSTALL THE STORMSACK ASSEMBLY DIRECTLY ON THE TRANSITION PLATE.

NOTES FOR 10135-5-500 STORMSOK ASSEMBLY AND 10101-5-000 EXPANSION RING:

- WEIGHT (EMPTY): 25 LB MAX
- MATERIAL:
 - A) SUPPORT FLANGE: ALUMINUM ALLOY PLATE, 5000 SERIES
 - B) STORMSOK: WOVEN POLYPROPYLENE GEOTEXTILE
 - C) APPARENT OPENING SIZE (AOS): 20 US SIEVE (840 MICRONS)
 - D) EXPANSION RING: ALUMINUM ALLOY CHANNEL, 6000 SERIES
 - E) HARDWARE: STAINLESS STEEL
- PERFORMANCE CHARACTERISTICS (TYP):
 - A) DEBRIS CAPACITY: 2.8 CU-FT
 - B) FILTERED FLOW RATE: 1750 GPM (3.9 CFS)
 - C) BYPASS FLOW RATE: 1077 GPM (2.4 CFS)
- DESIGNED TO FIT HARCO 30" ROUND CASTINGS
- RECOMMENDED MINIMUM STRUCTURE DEPTH: 2-IN BELOW STORMSOK
- USE WITH FABCO REPLACEABLE STORMSOK, P/N: 10135-5-102
- SHORT (12" LONG) STORMSOKS AVAILABLE ON REQUEST
- REPLACEABLE OIL BOOM AVAILABLE ON REQUEST

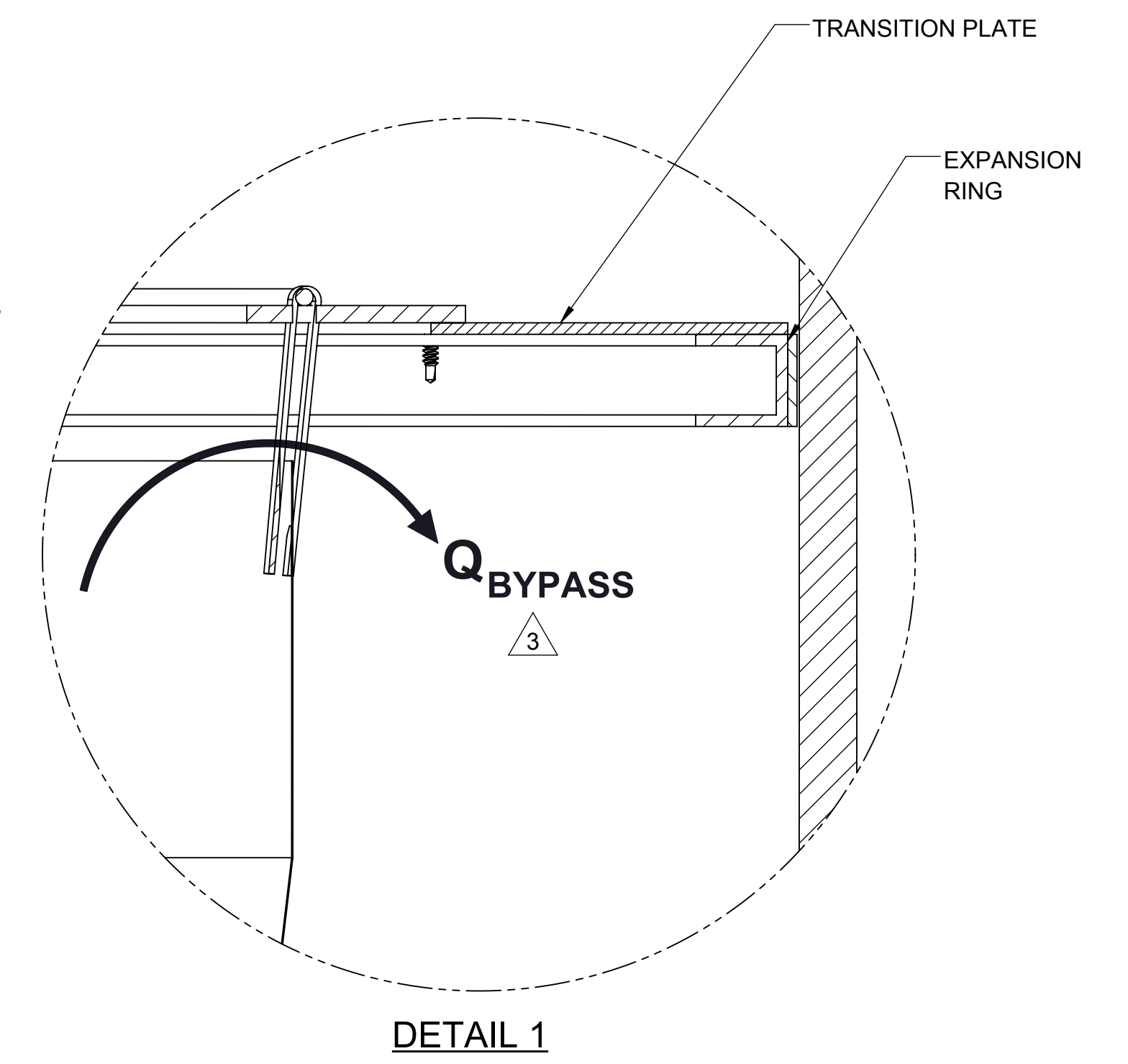
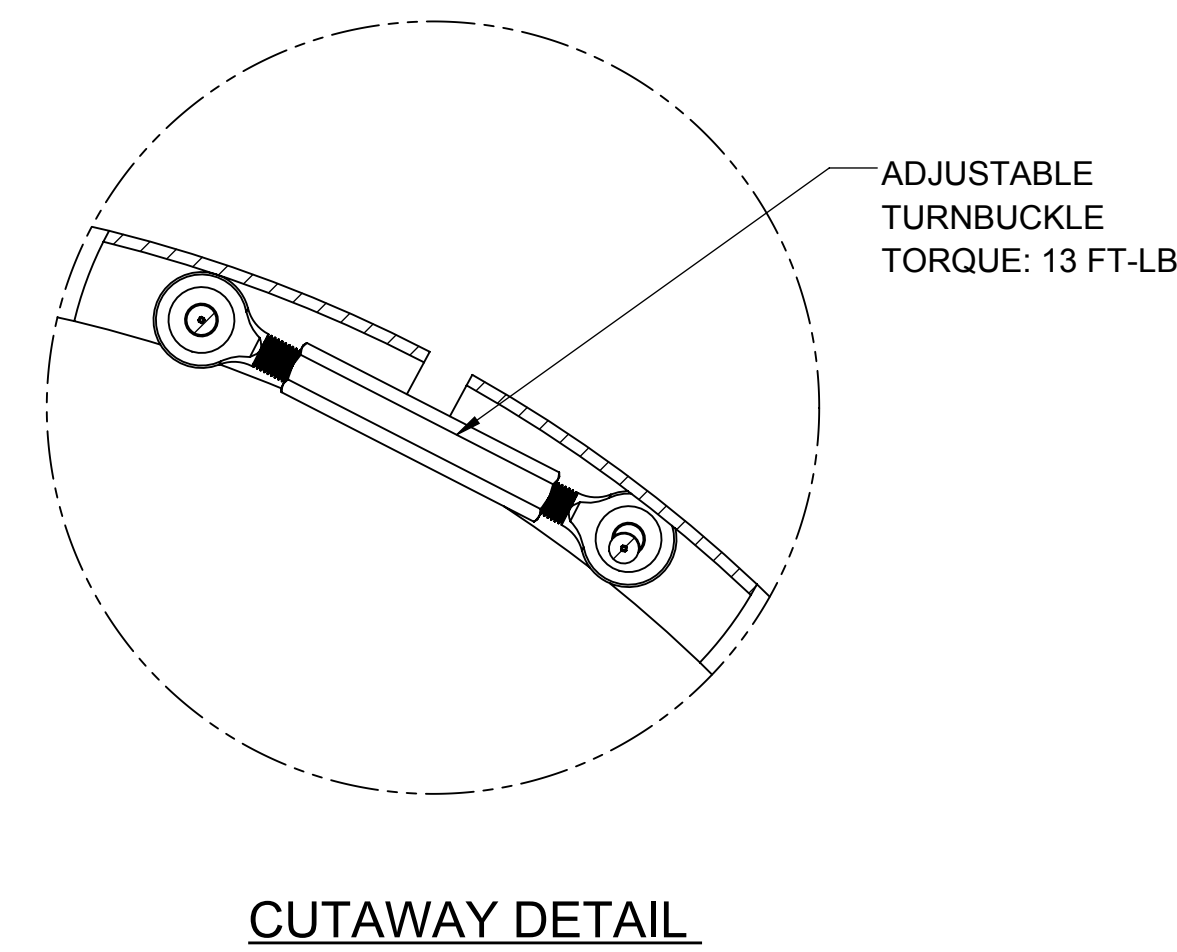
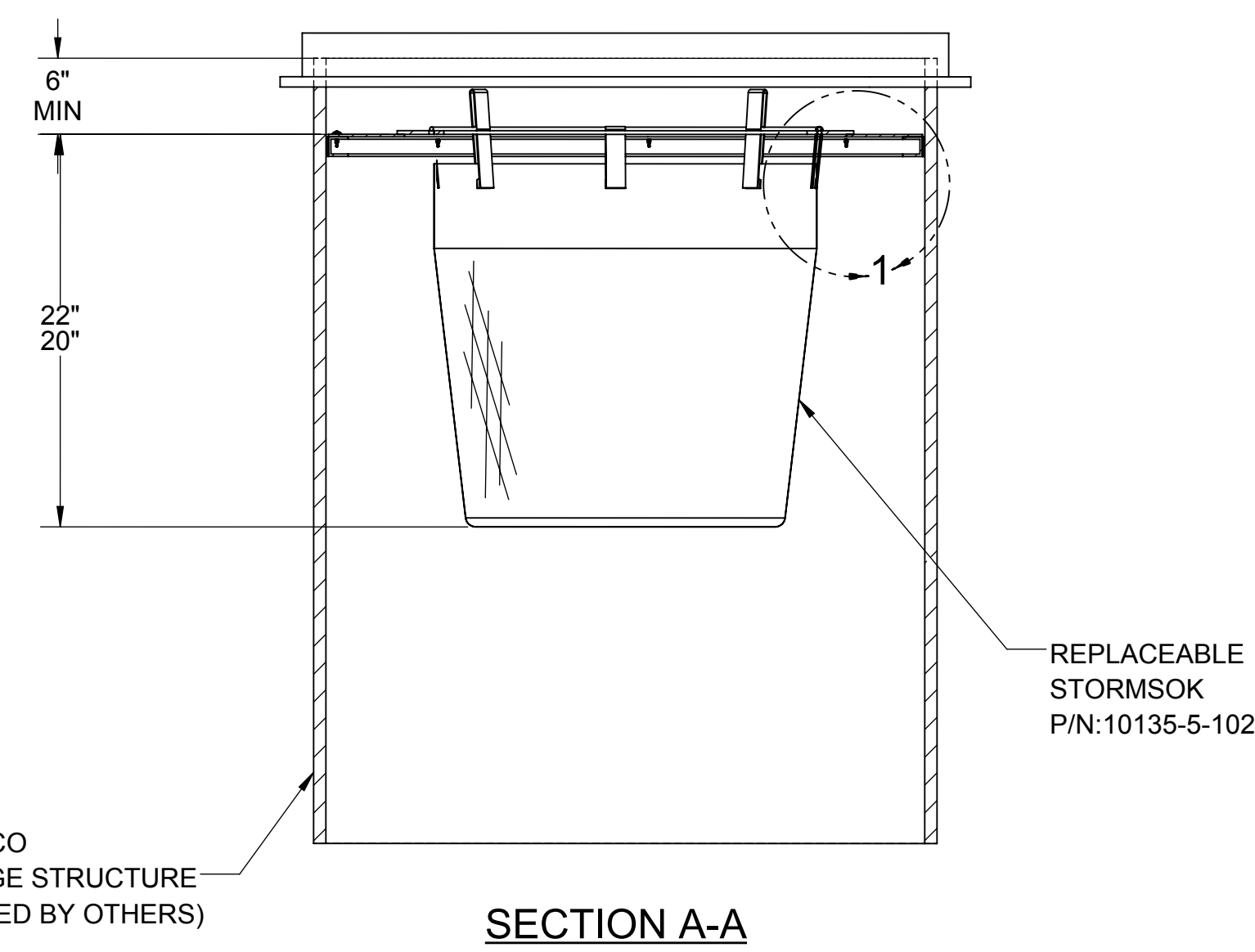

DESIGNED FOR USE WITH THE FOLLOWING HARCO CASTINGS

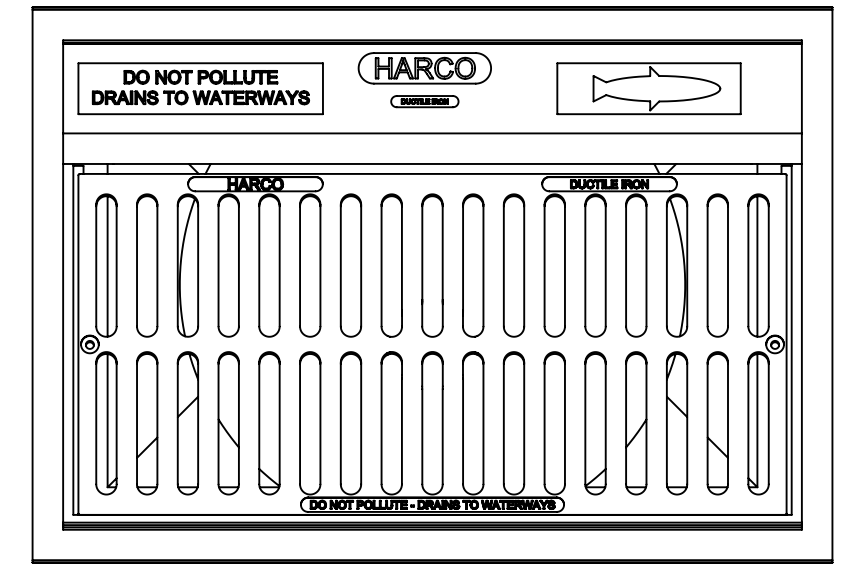
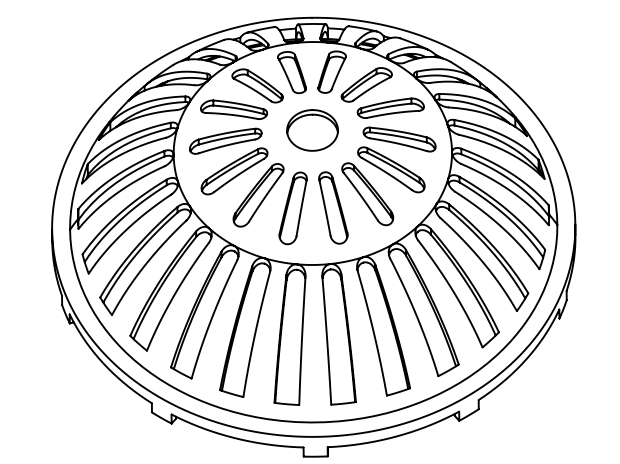
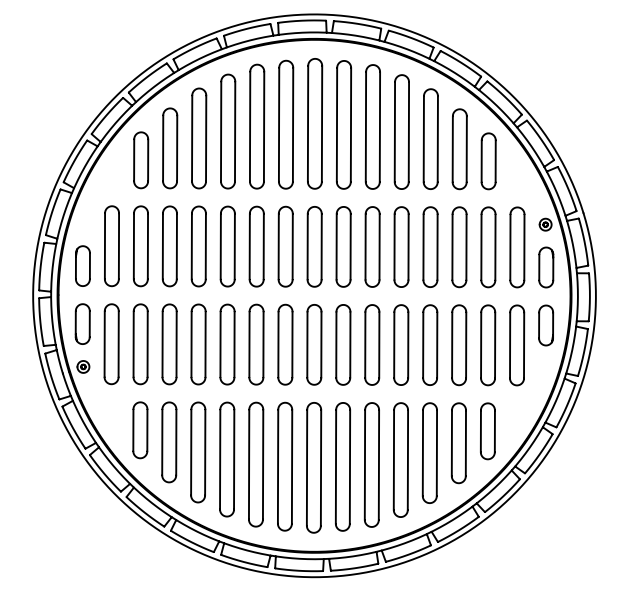

PROPRIETARY AND CONFIDENTIAL
 THIS DOCUMENT IS THE PROPERTY OF FABCO INDUSTRIES AND IS CONVEYED WITH THE EXPRESS CONDITION THAT IT AND THE INFORMATION CONTAINED IN IT ARE NOT TO BE USED, DISCLOSED, OR REPRODUCED IN WHOLE OR IN PART, FOR ANY PURPOSE WITHOUT THE EXPRESS WRITTEN CONSENT OF FABCO INDUSTRIES; AND THAT NO RIGHT IS GRANTED TO DISCLOSE OR SO USE ANY INFORMATION CONTAINED IN SAID DOCUMENT.

UNLESS OTHERWISE SPECIFIED REMOVE ALL BURRS BREAK SHARP EDGES .002 - .020 FILLETS .020 MAX DIMENSIONS ARE IN INCHES AND INCLUDE CHEMICALLY APPLIED OR PLATED FINISHES	TOLERANCES: DEC .00 ± .01 DEC .000 ± .005 FRACT ± 1/16 ANGLE ± 2°	APPROVAL	DATE
PROJECT	SEE NOTES	DWN MS	12/24/14
MATERIAL	SEE NOTES	CHKR JP	12/24/14
MODEL LINK	10135-5-000	ENGR ARVD	

FABCO INDUSTRIES, INC. 66 CENTRAL AVENUE FARMINGDALE, NY 11735 WWW.FABCO-INDUSTRIES.COM	
--	--

TITLE: STORMSOK AND EXPANSION RING FOR 30" ROUND HARCO STORM DRAIN	
SIZE: D	DWG. NO. 10135-5-000
SCALE: NONE	REV S
SHEET 1 OF 1	

